

GLOBE VALVE - LONG STEM

References: LSU1 / LRU2 / LSF13 / LRF14

Serie: 10101 (K.L.M.N.O.)

Applications: Cryogenic Liquids, LNG, Liquefied Gases

Phase: Liquid and Gas

Working Temperature: Maximum = +160° C / Minimum = -212°C

Working Pressure: 43 Bar / Hydrostatic Test: 65 Bar

Standards Applied: Cryogenic Bronze ASTM 93700, Valves and components provided cleaned for use in oxygen according to ASTM CGA G4.1



DIMENSIONAL TABLE (K. M.)

DN	MM	6	10	15	20	25	32	40	50	65	80	100
	Pol.	1/4"	3/8"	1/2"	3/4"	1"	1.1/4"	1.1/2"	2"	2.1/2"	3"	4"
Code		01	02	03	04	05	06	07	08	09	10	11
A		70	70	82	97	114	128	140	165	185	240	278
B		8	8	10	10	11	13	16	17	20	21	23
C		9.7	12.8	16.0	22.4	28.7	35.0	41.4	54.2	66.8	79.5	104.9
D (Opened)		367	367	367	379	379	444	444	456	562	576	685
E (Closed)		352	352	352	359	367	424	427	516	516	516	580
F		310.5	310.5	310.5	325	325	362	362	374	449	463	510
Ø Handwheel		90	90	90	90	110	110	110	110	250	250	300
Weight (Kg)		1.30	1.30	1.40	2.50	2.80	4.80	5.0	7.30	13.50	16.30	29.20
CV (gal/Min)		2.24	2.96	3.99	7.04	11.37	16.99	23.90	41.60	64.40	92.48	164.00

CONNECTION TABLE (L. N.)

Description	Code	Standard
NPT Threaded Connection	01	AISI B1.20
BSP Threaded Connection	02	AISI BESEN10226-1
Cooper Tube Fitting Connection	03	AISI B16.18
Stub Schedule 10, 50 mm	06	AISI B36.19
Stub Schedule 10, 100 mm	07	
Stub Schedule 40, 50 mm	08	
Stub Schedule 40, 100 mm	09	

SEAL TABLE (O.)

Description	Code	Standard
PTFE +25% Fiber Glass	04	N/A
PTFE +25% carbon	05	N/A

Opcional Table

Description	Code	Standard
Elongated Stem	001	MSS SP-134
Butt Weld	002	ASME B16.25
"C" Cote	003	N/A
Nickel Application	004	

outras conexões de acordo com a necessidade do cliente

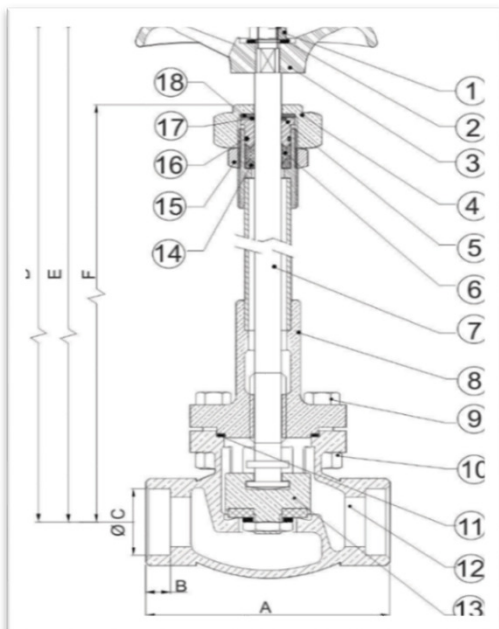

POS.	DESCRIPTION	MATERIAL
1	HEX NUT	BRASS UNS 26800
2	WASHER	STAINLESS STEEL AISI 304
3	HANDWHEEL	ALUMINUM SAE 306
4	PREMI NUT	BRASS UNS C36000
5	PREMI GASKET	BRASS UNS C36000
6	GASKET	PTFE ASTM D-1430-03
7	STEM	STAINLESS STEEL AISI 304
8	LONG HEAD	ASSEMBLED GROUP
9	HEX SCREW	STAINLESS STEEL AISI 304
10	HEX NUT	BRASS ASTM B-283
11	GARNISH	PTFE ASTM D-1430-03
12	BODY	BRONZE UNS C93700
13	SEAL	ASSEMBLED GROUP
14	WASHER	BRASS UNS C36000
15	NUT COUNT	BRASS UNS C36000
16	O'RING	VITON
17	O'RING	VITON
18	PRESSURE DISC	BRASS UNS C36000